

*Paper No: 07-IAGT, 1.5*

# INDUSTRIAL APPLICATION OF GAS TURBINES COMMITTEE

---



## Implementation of a Supersonic Ejector for Capturing Dry-Gas Seal Vent Gases

by

**K.K. Botros, J. Geerligs**

*NOVA Research & Technology Center, Calgary, Alberta, Canada.*

and

**H. Imran**

*TransCanada PipeLines Ltd., Calgary, Alberta, Canada.*

---

Presented at the 17th Symposium on Industrial Application of Gas Turbines (IAGT)  
Banff, Alberta, Canada – October 2007

1

The IAGT Committee is sponsored by the Canadian Gas Association. The IAGT Committee shall not be responsible for statements or opinions advanced in technical papers or in Symposium or meeting discussions.

### **K. K. Botros:**

Kamal K. Botros has a Ph.D. in Mechanical Engineering from the University of Calgary. Over the past 28 years he has worked on various fluid flow-equipment dynamic problems related to industrial facilities and petrochemical manufacturing plants. Initially, his research effort focused on solving problems related to the generation, transmission and suppression of flow generated pulsation, which resulted in the development of 'PULS', an industry standard acoustic simulation software used internationally. Later he focused his research activities on transient flow problems in complex systems, including centrifugal compressor surge phenomenon, pressure relief system dynamics, transients of two phase stratified flows, interface mixing between batches in pipelines, fluid-structure interactions and flow induced vibration in heat exchangers. He has contributed to the area of environmental mediation, including the development of supersonic gas ejector for capturing of gas emission, a Predictive Emission Monitoring (PEM) models, CO<sub>2</sub> emission abatement techniques for gas turbine based systems, and improve expelling techniques of combustible gases from confined spaces. Recent activities include: advances in stochastic methods and dynamic programming for multi-objective optimizations of large design space problems, and measurements of decompression wave speed following ruptures of high pressure rich gas pipelines. His research interests lie predominantly in time-dependent phenomena of fluids-equipment-structure interactions. Dr. Botros published over 115 technical papers in Journals and refereed conferences, and is a registered professional engineer in Alberta, Canada.

### **J. Geerligs:**

John Geerligs has a diploma in Electronics technology from the Northern Alberta Institute of Technology (NAIT) in Edmonton, Alberta, Canada. John began his career in electronic product development, with successful implementation of products for gas pipeline applications such as digital data collectors, inline pig tracking instrument and an insitu soil probe for mapping corrosion potential of soil near pipelines. He also contributed to the development of digital control for magnetic bearings and the development of a patented efficient power amplifier for magnetic bearings. For the past 10 years he has been conducting experimental research projects at the Gas Dynamics Test Facility (GDTF) near Didsbury Alberta, and his expertise is in applying the latest improvements in electronic instrumentation devices to the measurement and analysis of high pressure gas dynamic pressure and flow phenomena.

### **H. Imran:**

Hasan Imran has a Master's Degree in Chemical & Petroleum Engineering with specialization in Engineering for the Environment from University of Calgary, Alberta, Canada. His bachelor is in Chemical Engineering from Pakistan. Over the past 15 years he has worked within the petrochemical industry with a strong experience in the oil refining (atmospheric & vacuum distillation), gas processing, fertilizer and cement manufacturing. For the last 7 years he is working in the field of air issues and greenhouse gas emissions as well as corporate environmental management. He has worked on other emission mitigation research projects like methane emissions mitigation from small sources with use of biofilter using methanotrophic bacteria, use of incinerator for blowdown gas, use of fuel cell for low range remote power requirements.

Currently he is working as a Senior Environmental Advisor at TransCanada Corporation. He is responsible for Climate Change and Air issues related to existing natural gas pipeline and power plants along with new acquisitions. Development of Greenhouse Gas Emissions data management for the business, work strategy and accomplishments of its programs as well as coordinating Fugitive Emissions Management work across system, assisting in new programs and orientation. Most recently he has assisted in developing and implementing a web-based program to track environmental compliance and performance at facilities nationwide. He is also a registered professional engineer in Alberta, Canada.

## **Outline:**

1. Introduction
2. Dry-Gas Seal Leakage Rates
3. Primary Challenges of Supersonic Ejectors
4. Description of the First Stage
5. Description of the Second Stage
6. Performance of the Integrated Two-Stage Supersonic Ejector
7. Implementation Plan
8. Conclusions
9. Acknowledgment
10. References

## Abstract

The objective of the ejector device is to capture the gas leakage from a dry-gas seal at low pressure, and re-inject it into the fuel gas line to the gas generator (without the use of compressors or rotating elements), hence providing a means to utilize the gas that would otherwise be vented to atmosphere. The two primary benefits of this device are to eliminate the costs associated with the loss of the gas and to reduce greenhouse gas emitted by the dry-gas seal to the atmosphere. One of the main challenges to achieve the above goal lies in the fact that the leakage gas pressure is in the range of 70-340 kPag, while the minimum pressure required downstream of the fuel gas regulator is in the range of 2400–3400 kPag. The device consists of a two-stage supersonic ejector. The first stage is highly supersonic (nozzle exit Mach number  $\approx 2.54$ ), while the second stage is moderately supersonic (nozzle exit Mach number  $\approx 1.72$ ). Several tests were conducted on various configurations of the two stages on natural gas in order to arrive at the optimum design and operating parameters. The optimum design gave an expansion pressure ratio (motive/suction) of the order of 14.0 and compression pressure ratio (discharge/suction) of around 8.1. These ratios would meet the requirement of the minimum suction and discharge pressure mentioned above.

This paper firstly summarizes the optimum configuration arrived at after several iterations of different geometries of the supersonic nozzles, particularly for the first stage ejector, and presents the performance test results of the integrated system. The second part of the paper describes a successful implementation of the supersonic ejector unit at one of TransCanada's compressor stations in Alberta, Canada, on a compressor-gas turbine unit rated at 24 MW.

## 1.0 Introduction

Ejectors are well known for their advantage of having no moving parts. No seals, no shafts, no packing, and thus no maintenance are also some of the distinct advantages over mechanical compressors or vacuum pumps, which often require elaborate maintenance programs. Their rugged construction and simplicity of design enables their reliable, maintenance-free use. Although they are considered inefficient in general, they are often used in a wide range of industrial applications such as power plants for the creation of vacuum [1], power and thrust augmentation [2,3], refrigeration and heat pump systems [4-6], gas-vapour recovery from oil storage tanks, transport of solids [7], oil production [8], aero-engine cooling [9], bubble-bed tower reactors and bioreactors [10]. Other applications can be found in reference [7].

The purpose of the present work is to extend the application of ejectors to capture gas leakage from dry gas seals and re-inject it into a higher-pressure fuel gas stream going to the combustor of the gas turbine driving the gas compressor. This would result in not only saving the leaking gas and utilizing it as a part of the fuel gas, but also eliminating hydrocarbon emissions to the atmosphere. Furthermore, there will be no additional energy requirements to drive this ejector, since its motive gas is basically drawn from the fuel gas line to the gas generator prior to throttling, i.e. line pressure. It is argued that re-injection of the leakage gas into the gas generator fuel gas line is a better option than directing it to a lower pressure utility fuel gas line (e.g. in boilers). This is because boilers typically operate intermittently (on/off), i.e. not always firing while compressor units are running.

The primary challenge to achieve the above lies in the fact that the leakage gas pressures from the first stage dry-gas seals are in the range of 70-340 kPag, while the minimum pressure required downstream of the fuel

gas regulator (typically Fisher 310A type) is in the range of 2,400–3,300 kPag, depending on the gas turbine model. Commercial ejectors typically work either in the subsonic or slightly supersonic regions, which limits the suction pressure with respect to the motive gas pressure. For example, Fletcher [11] documents a discharge pressure calculation curve showing that with motive gas at 7,000 kPa-a and suction gas pressure 350 kPa-a; the maximum discharge pressure that can be achieved is approximately 1400 kPa-a. The same curve indicates that for a motive pressure of 7,000 kPa-a, and a discharge pressure of 2,800 kPa-a, the minimum suction pressure is 900 kPa-a. In the same study it was also shown that for a discharge pressure of 4,100 kPa-a and a suction pressure of 1,300 kPa-a, the required motive gas pressure would be 10,300 kPa-a. This demonstrates the difficulties associated with meeting both the low suction pressure while discharging to a much higher pressure.

In order to overcome these difficulties, a two-stage supersonic ejector has been developed and tested [14] such that the first stage is highly supersonic (nozzle exit Mach number = 2.54), while the second stage is moderately supersonic (nozzle exit Mach number = 1.72). Several tests were conducted on various configurations of the two stages on natural gas in order to arrive at the optimum design parameter. In the end, the optimum design showed an expansion pressure ratio (motive/suction) in the order of 14.0 and compression pressure ratio (discharge/suction) of around 8.1.

This paper presents the optimum configuration arrived at after several iterations of different supersonic expansion nozzles, particularly for the first stage part, and presents the measured performance results of the integrated system that would meet the requirements of capturing the low pressure, low flow dry gas seal leakage and re-inject it into the fuel gas stream. The operation of the dry-gas seal should not be adversely impacted if the dry-gas seal vent gas pressure matches the pressure of the suction gas to the first stage ejector, as will be discussed later in the paper.

## 2.0 Dry-Gas Seal Leakage Rates

A Typical dry-gas seal is a non-contact end face seal in which the sealing mechanism is comprised of two rings: the first ring with grooves etched in the seal face, which rotates with the shaft, is known as the mating ring, while the second ring has a smooth face and is restrained from movement except along the axis of the shaft. A pair of these seals often co-exists; hence provide a two-stage sealing effect.

For successful operation, it is essential that a steady flow of clean seal gas be supplied to the gaps between the rings. The seal supply gas source must be at a higher pressure than that of the process gas that is being sealed in order for flow to occur. On overhung compressors only one dry seal is required, in which case the seal supply gas can be drawn from the compressor discharge, filtered, and supplied in a steady flow to the seal capsule. Most of the seal supply gas re-enters the process cavity, while a small volume (leakage) passes through the seal faces and is vented to atmosphere. The amount of gas leakage depends on the process pressure and rotating shaft diameter. Figure 1 gives an example matrix of the order of magnitude of the gas leakage from a typical 1<sup>st</sup> stage dry-gas seal.

The purpose of the present supersonic ejector development is to provide a means for capturing this gas leakage and re-injecting it into the fuel gas line so that the available energy can be used resulting in fuel savings, in addition to minimizing what would otherwise be greenhouse gas emissions.

### 3.0 Primary Challenges of Supersonic Ejectors

The primary challenge of supersonic ejectors lies in compressing the combined (motive + suction) gas in the supersonic diffuser part of the ejector. In particular, the diffuser throat has to be larger than the nozzle throat to account for stagnation pressure losses through jet entrainment/mixing and at the inlet of the converging supersonic section of the diffuser, otherwise a standing shock would appear inside the nozzle and destroy the desired expansion in the static pressure. One technique to swallow such a shock is to have variable throat diffuser [12,13], which cannot be implemented here, as it would complicate the design. In order to overcome this challenge, the diffuser throat was made slightly larger than needed, which would keep the standing shock slightly downstream of the diffuser throat, or at best at the throat.

In order to arrive at the optimum design of a fixed-geometry diffuser that could work with different nozzles of different throat areas, Computational Fluid Dynamics (CFD) analysis was carried out to discern the flow field, accompanied by extensive testing of various configurations. The results of these efforts were presented in [14], along with the methodology to arrive at the optimum configuration. The optimized nozzle/diffuser arrangement showed that the nozzle is clear from a standing shock wave, which is good for suction. It was also shown that the shock wave region in the diffuser section (which is the region where Mach number drops sharply from supersonic to subsonic, is located at the throat of the diffuser or slightly downstream. Patent applications of the above ejector configuration have been filed both in Canada and in the United States [15,16].

### 4.0 Description of the First Stage

Based on the above discussion, and in order to satisfy the relatively low suction pressure to match the dry-gas seal leakage pressure ( $\sim 400$  kPa-a), an ejector with a highly supersonic exit flow will have to be employed. This would also come with the challenge associated with compression of the same supersonic flow after entraining the dry-gas seal leakage gas in a supersonic diffuser. Recognizing the challenge, and in an attempt to optimize a certain design configuration that would minimize the impact of the inevitability of the presence of a shock wave at the throat of the supersonic diffuser, a flexible prototype has been designed and fabricated as shown in Fig. 2. This design not only allows for various geometry supersonic nozzles to be tested with a fixed geometry diffuser, but it also allows for fine adjustments of the position of the nozzle exit in relation to the diffuser inlet (either positively, i.e. inserted into the diffuser inlet section, or negatively, i.e. retrieved back with a gap in between nozzle exit and diffuser inlet).

The supersonic diffuser has an inlet diameter of 4 mm, a throat diameter of 3.5 mm and length of 8 mm, and an exit diameter of 18 mm. Inlet  $\frac{1}{2}$ -angle of the inlet section is  $4.7^\circ$ , while that of the exit section is  $5^\circ$ . Several supersonic converging/diverging nozzles were fabricated with different throat diameters and exit/throat area ratios. The best performance configuration was obtained with the 1.6 mm (throat) x 2.8 mm (exit) nozzle placed at 20.5 mm inside the supersonic diffuser. Test results of this 1<sup>st</sup> stage ejector with this nozzle size are shown in Figs. 3 and 4 in terms of expansion ratio ( $P_1/P_2$ ), compression ratio ( $P_3/P_2$ ) and suction to motive gas flow ratio. It is shown that an expansion ratio of 20 and compression ratio of 3.5 has been achieved with motive gas pressure ( $P_1=5,000$  kPa-a).

## 5.0 Description of the Second Stage

The second stage ejector was sized and designed such that it would use the full line gas pressure as motive gas without throttling, and discharge at a pressure ( $P_{out}$ ) up to 3,400 kPa-a (as depicted in Fig. 5). The suction flow to this 2<sup>nd</sup> stage is the exit flow from the 1<sup>st</sup> stage ejector. Numerical simulation involving a one-dimensional gas dynamics model through the 2<sup>nd</sup> stage supersonic nozzle was performed to arrive at the nozzle area ratio, from which a nozzle exit to throat area ratio of 1.382 was selected such that the nozzle exit pressure matches the outlet pressure from the 1<sup>st</sup> stage ejector.

CFD simulations were then utilized to optimize the best supersonic diffuser dimensions (throat, inlet, and outlet diameters, as well as angles) and position of the nozzle with respect to (w.r.t.) diffuser inlet. The optimum design of the 2<sup>nd</sup> stage is shown in Fig. 6.

## 6.0 Performance of the Integrated Two-Stage Supersonic Ejector

Figure 7 shows the integrated test rig with the two-stage ejector and the corresponding pressures, temperatures and mass flow rate measurements. Tests were conducted on the 2<sup>nd</sup> stage ejector alone in order to optimize the position of its supersonic nozzle w.r.t. the diffuser inlet. The best performance was obtained with the position of the nozzle exit at 1.42 mm *upstream* from the inlet section of the supersonic diffuser in this 2<sup>nd</sup> stage ejector. Tests were then conducted on the two-stage ejector configuration combined, by varying  $P_1$  to the 1<sup>st</sup> stage ejector (4600 kPa-a, 5,000 kPa-a and 5,500 kPa-a), while maintaining the motive gas pressure ( $P_{in}$ ) to the 2<sup>nd</sup> stage ejector at maximum line pressure of approximately 6,000 kPa-a. Figures 8 through 10 show the results of the integrated two-stage ejector system in terms of the discharge pressure from the 2<sup>nd</sup> stage ejector (Fig. 8), suction flow at the 1<sup>st</sup> stage (Fig. 9), and the intermediate pressure ( $P_3$ ) for different  $P_1$  (Fig. 10). The effects of varying ( $P_1$ ) are manifested in Fig. 8, which indicates that the lower the  $P_1$  the higher the suction flow, but at the expense of the overall discharge pressure ( $P_{out}$ ).

The good news is that the present optimized configuration is capable of delivering the required discharge pressure ( $P_{out}$ ) of 3300 kPag with a suction flow of 2-2.5 kg/hr and suction pressure ( $P_2$ ) of 340 kPag. These values are matching the requirements for this ejector to work with a dry-gas leakage and a typical fuel gas line on a typical compressor station. Motive gas flow to the 1<sup>st</sup> stage is 0.016 kg/s (based on 5000 kPa-a pressure), and to the 2<sup>nd</sup> stage is 0.464 kg/s (based on 6000 kPa-a pressure).

Recognizing that the motive gas to the 2<sup>nd</sup> stage ejector is drawn from the compressor discharge side (~ 6000 kPag), an assessment should be made to the balance-of-plant w.r.t. net energy saved by capturing the vent gas from the dry-gas seal. Based on compressor suction pressure of ~ 5000 kPag, pressure ratio of 1.2, the excess power drawn by the motive gas flow of 0.464 kg/s is 9.3 kW. Assuming a thermal efficiency of the gas turbine/compressor set of 30%, the extra fuel usage due to compressing the motive gas is 31 kW. Now, the gas saving resulting from capturing the dry-gas seal vent gas of 9.0 kg/hr amounts to 130 kW (based on gas heating value of 39.3 MJ/s.m<sup>3</sup>). Therefore, the net energy saving in fuel gas would be approximately 99 kW. The more important effect of employing the supersonic ejector is rather the substantial reduction in the GHG as shown by the calculations in Table 5. It is demonstrated that the net effect of employing the ejector is approximately a reduction of 1600 tonnes of CO<sub>2</sub>-E per year.

## 7.0 Implementation Plan

TransCanada plans to implement the newly developed gas-gas ejector system at its compressor stations system wide based on results through real-time testing on a 24 MW compressor unit at one of its compressor stations in Alberta, Canada. The present integrated two-stage ejector system has been skid mounted with additional pressure gauges (shown as a shaded area in Fig. 11). The centrifugal compressor unit that was selected as a pilot was chosen because of its high utilization hours, so as to test the performance of the ejector system on a wide range of operating conditions and fluctuating loads. One of the other considerations in selecting the compressor unit was the ease of shutting down the unit without interrupting the transmission service to customers. The seal gas leak line currently going to atmospheric vent has a flow meter and a check valve. Table 1 gives the compressor operating parameters, Table 2 gives the primary gas seal parameters both at the drive-end (DE), and non-drive-end (NDE), and Table 3 gives details of the fuel gas system pertaining to the selected compressor unit. The concept of the implementation design was based on these two sets of parameters. Figure 11 shows that the two primary dry-gas leakage lines from the two DE and NDE dry-gas seals are connected to form the suction to the first stage ejector. Two check valves are shown to prevent any back flow into the seal area.

The existing dry-seal monitoring system was modified slightly by adding backpressure regulators on the seal vents. The back pressure currently at 160 kPag, was increased to 500 kPag. The existing rupture discs rating will remain the same at approximately 700 kPag, while shutdown setpoint was set at 600 kPag. In the event that the ejector could not suck gas from the primary vent, these two regulator valves will vent off the gas to atmosphere so as not to risk the dry-gas seal. The rupture discs will continue to provide the same functions if the pressure increases above 700 kPag. The increase in the back pressure on the primary seal from 160 kPag to 500 kPag will not have any adverse impact on the integrity of the dry gas seal. This was reviewed and assured by the specific seal manufacturer of the unit.

For the first stage motive gas, a tie-in line was taken from the outlet of the fuel gas filter and upstream of the Fisher 310 control valve. This pressure varies between 4,600-5800 kPag. Second stage motive gas was supplied from compressor discharge line downstream of the unit valve, typically 6,000-6600 kPag. Using these two motive gas lines, the two-stage ejector operating parameters (pressures, temperatures and flow rates) at different locations marked with numeric numbers in Fig. 11, are given in Table 4. It is noted that, due to the supersonic nature of the two stages, the gas expansion through the respective nozzles will result in extremely cold gas temperatures, which correspond to conditions inside the gas two-phase envelope (Fig. 12). However, the exit velocity of the gas from the supersonic section is extremely high, which will not allow for thermodynamic equilibrium. Even if small condensation droplets could form, these will be moved at enormous velocity into the diffuser section of the respective stage, and will evaporate due to compression in the diffuser.

A gas coalescer filter is installed on the ejector skid at location 5 (see Fig. 11 and photo of Fig. 13) to filter the final discharge gas from the ejector before entering into the fuel gas line. This is because buffer gas is used to flush the seal chamber of debris or dirty gas and to keep the environment in the seal clean. It is expected that there could be some buffer gas leaking into the primary seal gas system and eventually to the fuel gas through the ejector. Hence the design is calling for this coalescer filter as shown in Fig. 11.

One concern that was raised was in regard to the fact that a higher backpressure on the primary dry-gas seal could result in gas migrating to the secondary dry seal, located near to the magnetic bearing cavities. If the purge air fails and this gas migrates into the magnetic bearing cavities, and an ignition source within the magnetic bearing cavities exists, an explosion could result. It was, however, argued that it is highly unlikely



for an ignition source to be generated within the magnetic bearing cavities during startup, shutdown, and bearings being de-energized. Additionally, an expert on bearing design ascertained that it would be very difficult for gas to get into the bearing chamber, because there is an outer seal labyrinth on the gas seal that has barrier air going to it, outboard of the secondary vent. Therefore, any gas that gets across the secondary seal will be pushed out to the secondary vent by the barrier air, which should be vented to atmosphere. There is also an air purge to the bearing chambers and they are also vented to atmosphere. Therefore, there is a positive pressure on the bearing housings that should help keep process gas from entering. Additionally, the barrier labyrinth should also help in preventing the combustible gas from migrating into the magnetic bearing chamber. Therefore, as long as the system is working properly, with barrier air flowing, there should not be any process gas getting into the bearing chamber. Furthermore, the magnetic bearing design does not have an ignition source since the whole magnetic bearing assembly is sealed and should be contact-free (rotor and stator) with an air gap that provides the dampening and the magnetic field needed to achieve its function. Finally, there is a differential pressure monitoring device which (if works properly) will trigger a unit to shut down on reversed pressure differential between the magnetic bearing cavities and the secondary dry seal, i.e. purge air and/or the seals fail.

The supersonic ejector skid was installed next to the fuel gas system to the GT unit as shown in the photos of Fig. 13. The system was commissioned on June 23, 2007. Data were collected after successful commissioning and shown in Table 6. The ejector unit continued to accumulate operation hours to July 20, 2007 when another set of data were taken and given in Table 7.

## 8.0 Conclusions

It was shown that the two-stage ejector is capable of capturing a low-pressure gas akin to that being vented from a typical 1<sup>st</sup> stage dry-gas seal, and discharge it for re-injection into a higher-pressure stream at 3,400 kPa-a for fuel gas utilization. The following conclusions can be made from the above discussion:

1. It is possible to achieve a very high expansion ratio (even higher than 20 times) with a supersonic nozzle. The challenge is always in the recompression of the expanded gas to an intermediate pressure through a converging diverging diffuser.
2. For the application of a supersonic ejector for the purpose of capturing the vent gas from the primary dry-gas seal, a two-stage ejector was developed. Expansion of the motive gas in the first stage ejector nozzle is easy. However, recompression to a pressure equal to the fuel gas pressure was the challenge, and that necessitated the second stage to boost the gas pressure to an adequate level.
3. Implementation design concept and analysis indicated that the above implementation plan, which attended to operational and functional details of both the primary and secondary seals, as well as the adjacent magnetic bearing chamber, is achievable.
4. The supersonic ejector system depicted in Fig. 11 was installed and commissioned successfully on an 24 MW GT unit in one of TransCanada's compressor stations in Alberta, and is currently accumulating hours of operation.

## 9.0 Acknowledgment

The authors wish to thank Bruce Huynh and Barry Nilsson (TransCanada) for their undertaking to implement the supersonic ejector on a TransCanada Compressor station in Alberta, Dwayne Krause (Expert on Dry Gas Seal Technology) for valuable assistance in designing the overall system, and Vladimir Bakalchuk (of John Crane) and Sorin Necula (Dresser-Rand) for valuable consultation during the initial phase of the implementation plan. Direction, encouragement, and unconditional support from Brian McConaghy and Liz Sirakowski (TransCanada) are greatly appreciated. Their leadership and commitment towards clean air and the environment are commendable and much valued. Thanks are also due to Thomas Robinson and Anthony Tse (TransCanada) for their continuous support and promotion of technology. Thorough review of the paper and recommendations made by Chris Foy and Robert McBrien are much appreciated. Finally, this work is part of a research program sponsored by TransCanada PipeLines Ltd., and permission to publish it is gratefully acknowledged.

## 10. References

1. Power, R.B.: "Predicting Unstable-Mode Performance of a Steam Jet Ejector", Fluid Power Systems Technology, Collected Papers, ASME, 1994.
2. Freeman, B.Z. and Lior, N.: "A Novel High-Temperature Ejector-Topping Power Cycle", J. Eng. For Gas Turbines and Power, vol. 116, pp. 1-7, January 1994.
3. Minardi, J.E.: "Compressible Flow Ejector Analysis with Application to Energy Conversion and Thrust Augmentation", AIAA 20<sup>th</sup> Aerospace Sciences Meeting, Paper # 82-0133, Orlando, Florida, January 11-14, 1982.
4. Huang, B.J. and Chang, J.M.: "Empirical Correlation for Ejector Design", International Journal of Refrigeration, Vol. 22, pp. 379-388, 1999.
5. Huang, B.J., Chang, J.M., Wang, J.M. and Petrenko, V.A.: "A 1-D Analysis of Ejector Performance", International Journal of Refrigeration, Vol. 22, pp. 354-364, 1999.
6. Chen, S.L., Yen, J.Y. and Huang, M.C.: "An Experimental investigation of ejector performance based upon different refrigerants", ASHRAE Transactions, vol. 104 no. 2, pp. 153-160, June 1998.
7. Sun, Da-Wen and Eames, I.W.: "Recent Developments in the Design Theories and Applications of ejectors - a Review", Journal of the Institute of Energy, vol. 68, no. 475, pp. 65-79, Jun 1995.
8. Villa, M., De Ghetto, G., Paone, F., Giacchetta, G. and Bevilacqua, M.: "Ejectors for Boosting Low-Pressure Oil Wells", SPE Production and Facilities, vol. 14, no. 4, pp. 229-234, Nov 1999.
9. Hu, H., Kobayashi, T., Saga, T., Taniguchi, N., Liu, H. and Wu, S.: "Research on the Rectangular Lobed Exhaust ejector/mixer Systems", Transactions of the Japan Society for Aeronautical and Space Sciences, vol. 41, no. 134, pp. 187-194, 1999.
10. Zahradnik, J., Fialova, M., Linek, V., Sinkule, J., Reznickova, J. and Kastanek, F.: "Dispersion Efficiency of Ejector-type Gas Distributors in Different Operating Modes", Chemical Engineering Science, vol. 52, no. 24, pp. 4499-4510, Dec 1997.
11. Fletcher, G.R.: "Gas Jet Compressors", Petroleum Refiner, pp. 107-111, February, 1954.
12. Shapiro, A.H., The Dynamics and Thermodynamics of Compressible Fluid Flow – Vol. 1", E. Krieger Publishing Co., Malabar, Florida, pp. 972-973, 1983.
13. Zucrow M.J. & Hoffman J.P. Gas Dynamics, Vol. I, John Wiley & Sons Inc., 1976.
14. Botros, K.K., Geerligs, J., Imran, H. and Thompson, W.: "Development of a Supersonic Ejector for Capturing Very Low Pressure Vent Gases and Re-injection into a High Pressure Stream", 6th International Pipeline Conference, Calgary, Alberta, Canada, September 25-29, 2006.

15. Botros, K.K., Geerligs, J. and Imran, H.: “Tandem Supersonic Ejector”, Canadian Patent Application, September, 2006.
16. Botros, K.K., Geerligs, J. and Imran, H.: “Tandem Supersonic Ejector”, U.S. Patent Application, May, 2007.

**Table 1: Operating Parameters of the Selected Compressor Unit for the Implementation of the Supersonic Ejector.**

<b>Unit #1:</b>		
Suction Pressure	4,613.00	kPa-g
Suction Temperature	15.60	C
Discharge Pressure	5,801.00	kPa-g
Discharge Temperature	34.70	C
PT Speed	5,589.00	RPM
Ad. Eff.	79.00	%
Flow	6,715.00	E6M3/d
Flow	58.29	kg/s

**Table 2: Operating Parameters of the DE and NDE of the Dry-Gas Seal on the Compressor Unit Selected for the Implementation of the Supersonic Ejector.**

<b>Drive End 1st Stage Seal Vent Gas:</b>					
Pressure	35	kPa-g	Alarm Pressure	80	kPa-g
Flow	5	SCFM	S/D Pressure	160	kPa-g
Flow	0.002	kg/s	Rupture Disc PSE 1203	700	kPa-g
<b>Non-Drive End 1st Stage Seal Vent Gas:</b>					
Pressure	6	kPa-g	Alarm Pressure	80	kPa-g
Flow	2.5	SCFM	S/D Pressure	160	kPa-g
Flow	0.001	kg/s	Rupture Disc PSE 1204	700	kPa-g

**Table 3: Operating Parameters of the Fuel Gas System on the Compressor Unit Selected for the Implementation of the Supersonic Ejector.**

<b>Fuel Gas:</b>		
Inlet Pressure	4,610.00	kPa-g
Inlet Temperature	15.60	C
Pressure After Heater	4,500.00	kPa-g
Temp After Heater	36.00	C
Pressure After 310	2,700.00	kPa-g
Temp After 310	23.00	C
Flow	135.60	E3M3/d
Flow	1.18	kg/s

**Table 4: Design Parameters of the Supersonic Ejector Specific to the Compressor Unit Selected for Implementation.**

Location # (Refer to Fig. 11)	P (kPa-a)	T (°C)	Mass Flow (kg/s)
1	4600	35.9	0.016
N1	350	-113.0	0.016
2	350	10.0	0.001
3	1219	12.7	0.017
4	6000	35.0	0.464
N2	1219	-68.0	0.464
5	3260	8.2	0.481
6	4600	35.0	1.177
7	4600	35.0	0.696
8	2500	23.0	0.696
9	2500	18.4	1.177

**Table 5: Calculation of the Benefit of the Supersonic Ejector on GHG Emission.**

Ejector 2nd stage motive flow	0.4634	kg/s
Motive gas extra power needed	9,300	W
Motive gas turbine extra fuel needed	31,000	W
Fuel heating value	39	MJ/m <sup>3</sup>
Fuel heating value	52,000,000	J/kg
Fuel gas burned	0.00059615	kg/s
GHG CO <sub>2</sub> from above burning	0.00155	kg/s
GHG CO <sub>2</sub> from above burning	48.8808	tonnes/year
Captured Dry-seal vent gas	9	kg/hr
Captured Dry-seal vent gas	0.0025	kg/s
Heat Energy Equivalent	130,000	W
Heat Energy Saving	99,000	W
GHG CO <sub>2</sub> -E of the captured gas	0.0525	kg/s
GHG CO <sub>2</sub> -E of the captured gas	1,656	tonnes/year

**Table 6: Actual Operating Data Collected After Successful Commissioning of the Supersonic Ejector (Data Collected on June 23, 2007).**

Location # (Refer to Fig. 11)	P (kPa-a)	T (°C)	Mass Flow (kg/s)	Mass Flow (kg/hr)
1	5090	35.9	0.01770	63.720
DE Seal	506	10.0	0.001607	5.785
NDE Seal	512	10.0	0.001607	5.785
Total Seal Leakage	509	10.0	0.003214	11.570
N1	509	-113.0	0.01770	63.720
2	509	10.0	0.00286	10.285
Vent to Amb	509	10.0	0.00036	1.285
3	1190	12.7	0.021	74.005
4	5990	35.0	0.463	1668.240
N2	1190	-68.0	0.463	1668.240
5	2990	8.2	0.484	1742.245
6	5140	10.0	1.177	4237.500
7	5090	35.9	0.693	2495.255
8	2900	23.0	0.693	2495.255
9	2690	18.4	1.177	4237.500

**Table 7: Actual Operating Data Collected After one Month of Continuous Operation of the Supersonic Ejector (Data Collected on July 20, 2007).**

Location # (Refer to Fig. 11)	P (kPa-a)	T (°C)	Mass Flow (kg/s)	Mass Flow (kg/hr)
1	5800	35.9	0.02017	72.612
DE Seal	512	10.0	0.00214	7.704
NDE Seal	517	10.0	0.001696	6.106
Total Seal Leakage	515	10.0	0.003836	13.810
N1	515	-113.0	0.02017	72.612
2	515	10.0	0.00250	9.000
Vent to Amb	515	10.0	0.00134	4.810
3	1400	12.7	0.023	81.612
4	6540	35.0	0.506	1820.880
N2	1400	-68.0	0.506	1820.880
5	3160	8.2	0.528	1902.492
6	5850	10.0	1.177	4237.500
7	5800	35.9	0.649	2335.008
8	3100	23.0	0.649	2335.008
9	2690	18.4	1.177	4237.500

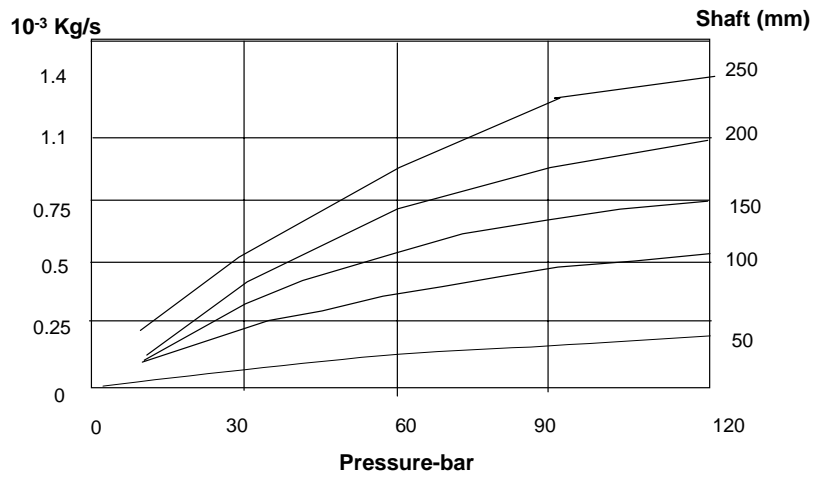

**Figure 1: Typical Dynamic Gas Leakage Rate from the 1<sup>st</sup> Stage Dry-Gas Seal.**

BILL OF MATERIALS											
ITEM	QTY	DESCRIPTION	PART NO.	REV	MATERIAL	ITEM	QTY	DESCRIPTION	PART NO.	REV	MATERIAL
1	1	1/2" ANSI 600# WN FLANGE	PURCHASE	0	SA-182 F44	9	1	SUPERSONIC DIFFUSER	HT-EE-A-3137-C	0	SA-479 316
2	1	1"X5 1/4 BAR	HT-EE-A-3137-F	0	SA-479 316	10	2	1-1/2" ANSI 600# WN FLANGE		0	SA-182 F44
3	1	LOCKNUT 1-1/4" OD.X0.5"	HT-EE-A-3137-D	0	SA-479 NITRONIC 60	11	1	REDUCER 1-1/2"x1"	HT-EE-A-3137-R	0	SA-403 WP304 OR WP316
4	1	NOZZLE HOLDER 1-1/2" OD.X5-3/4"	HT-EE-A-3137-A	0	SA-479 NITRONIC 60	12	1	1" ANSI 600# WN FLANGE		0	SA-182 F44
5	1	BEARING LOCKNUT 2-1/4" OD.X3/4"	HT-EE-A-3137-E	0	SA-479 316	13	2	GASKET 1-1/2"ID.X3"OD. 0.031" THICK	KLINGER OLIT 3XA	0	
6	1	WASHER	HT-EE-A-3137-G	0		14	1	3/4" ANSI 600# WN FLANGE		0	SA-182 F44
7	1	REDUCER TEE 1-1/2"x3/4"		0	SA403 WP304 OR WP316	15	2	O-RING	#025		FLUORSILICONE
8	1	SUPERSONIC NOZZLE	HT-EE-A-3137-B	0	SA-479 316	16	2	O-RING	#018		FLUORSILICONE
17	1	PIPE 2" OD.X1-3/4"	HT-EE-A-3137-W1	0	SA-479 316	18	1	O-RING	#027		FLUORSILICONE

DESIGN DATA  
 MAWP = 1440 PSIG @ -49/167°F  
 OPERATING MEDIUM: NATURAL GAS

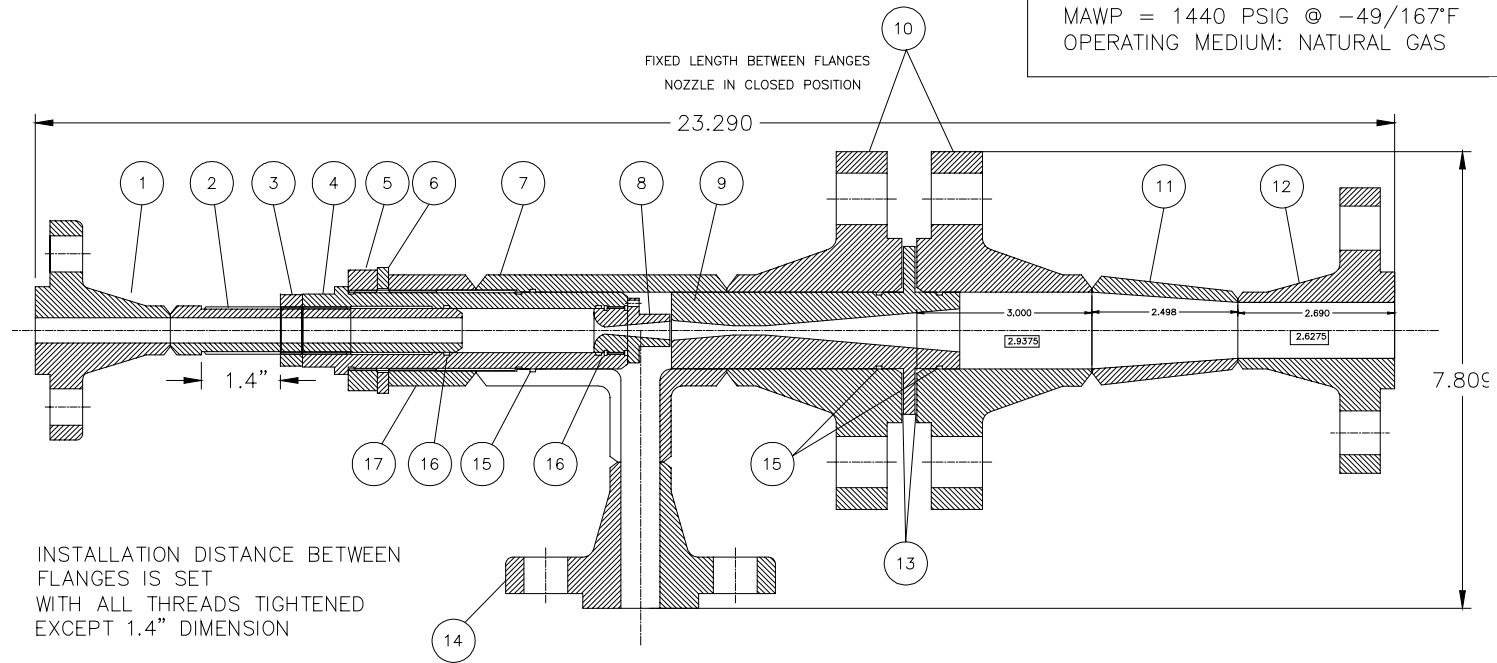

Figure 2: Design Details of the 1<sup>st</sup> Stage Supersonic Ejector.



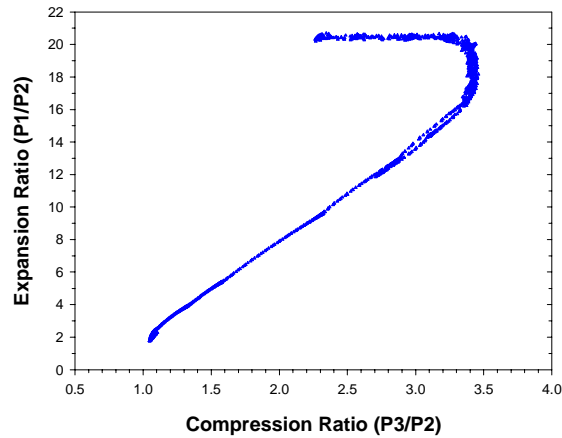

Figure 3: Expansion and Compression Characteristics of the Best Performing 1<sup>st</sup> Stage Ejector.

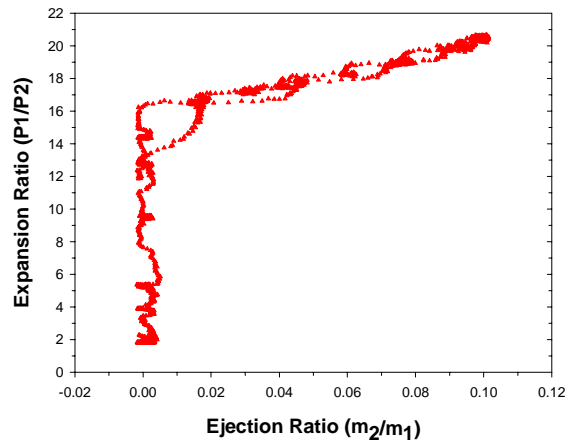

Figure 4: Ejection Mass ratio of the Best Performing 1<sup>st</sup> Stage Ejector.

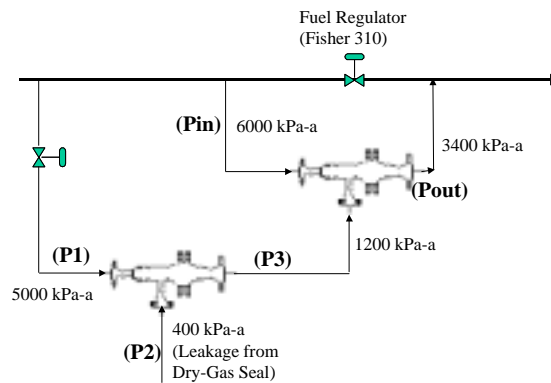

Figure 5: Conceptual Configuration and Design Pressures of the Two-Stage Ejector.

**APPLICABLE CODES:**

- ASME B16.5
- ASME B31.3-2002
- ASME B&PV SECTION VIII, DIV 1, -2003
- CSA B51-97

**SERVICE:**

- NORMAL, NATURAL GAS, METHANE

**STAMPING PER ASME B 16.5:**

- MANUFACTURER'S NAME OR TRADE MARK
- ASTM SPECIFICATION NUMBER AND GRADE PER TABLE 1
- B16.5 NPS 2 CLASS 600
- TEMPERATURE RATING PER TABLE 1
- MAXIMUM PRESSURE RATING PER TABLE 1

TABLE 1 MAXIMUM WORKING PRESSURE/TEMPERATURE RATINGS PER ASME B16.5			
MATERIAL	APPLICATION TEMP DEG. F	PRESSURE PSIG	HYDROSTATIC TEST PRESSURE PSIG
ASTM-SA350/LF2-CL1	-50 TO 167(75°C)	1392	2160
ASTM-SA182-F316	-50 TO 167(75°C)	1306	2027
ASTM-SA350/LF3	-50 TO 167(75°C)	1500	2328
ASTM-SA182-F44	-50 TO 167(75°C)	1459	2264

**BILL OF MATERIALS**

ITEM	QTY	DESCRIPTION	PART NO.	MATERIAL
1	1	HOUSING	0003	SEE TABLE
2	1	DIFFUSER	0004	AISI 1144
3	1	NOZZLE	0005	AISI 1144
4	1	CAGE	0006	AISI 1144
5	1	0.200 INCH SPACER	0007	AISI 1144
6	1	ORING 2-126	0008	VITON DUROMETER 70
7	1	ORING 2-133	0009	VITON DUROMETER 70
8	1	ORING 2-121	0010	VITON DUROMETER 70
9	4	4-40 UNS SHCS X 1/4	0011	GRADE 8 OR EQUIVALENT
10	1	RETAINING RING	0012	SMALLEY WHM-193 SS
11	1	0.200 INCH SPACER	0007	AISI 1144

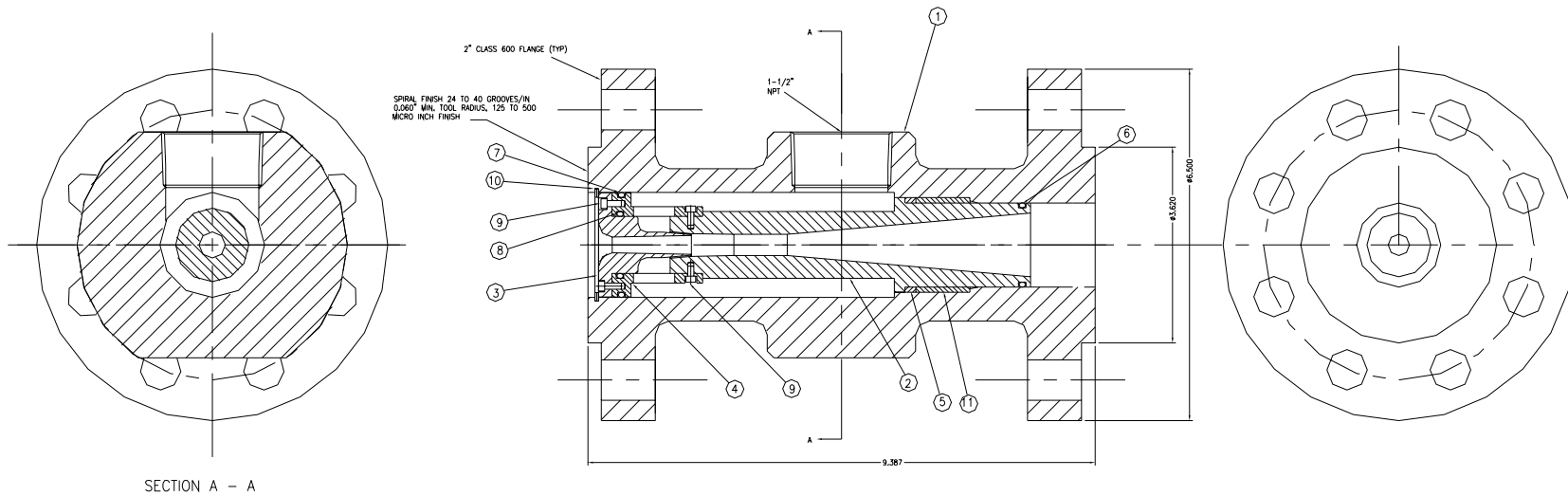

**Figure 6: Design Details of the 2<sup>nd</sup> Stage Supersonic Ejector.**

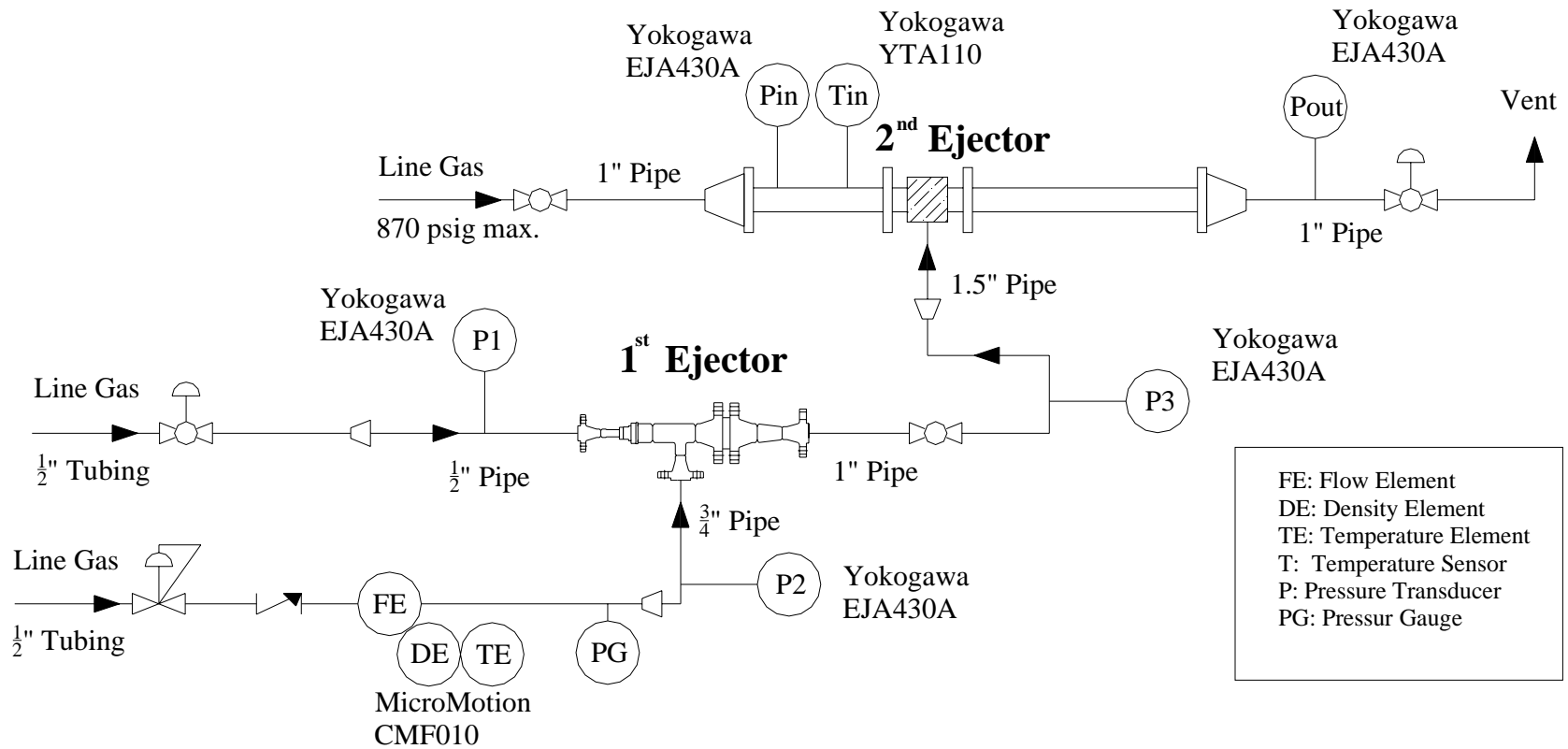
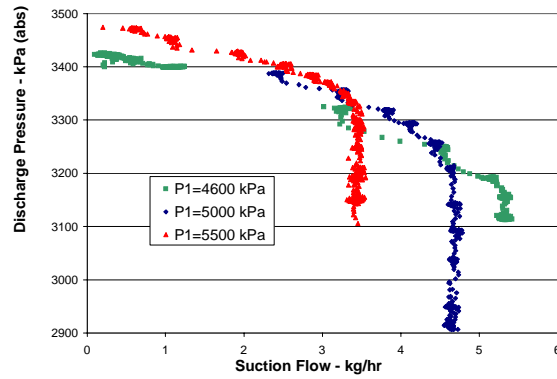
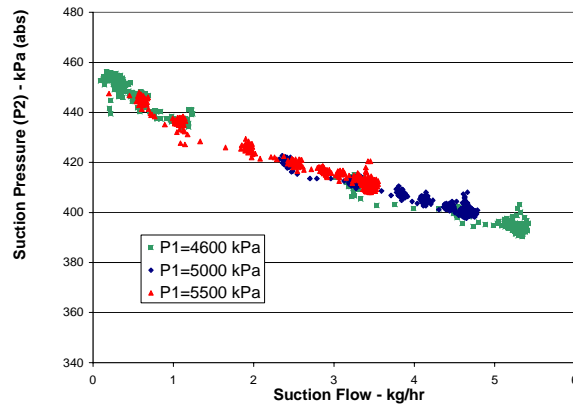

Figure 7: Schematic of the Two-Stage Supersonic Ejector Test Rig.



**Figure 8: Overall Performance of the Two-Stage Supersonic Ejector (Discharge pressure from 2<sup>nd</sup> stage vs. suction flow at 1<sup>st</sup> stage).**



**Figure 9: Overall Performance of the Two-Stage Supersonic Ejector (Suction pressure vs. suction flow at 1<sup>st</sup> stage).**

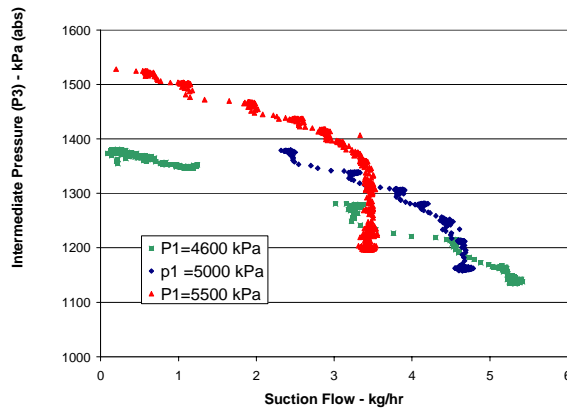

**Figure 10: Overall Performance of the Two-Stage Supersonic Ejector (Intermediate pressure between the two stages vs. suction flow at 1<sup>st</sup> stage).**

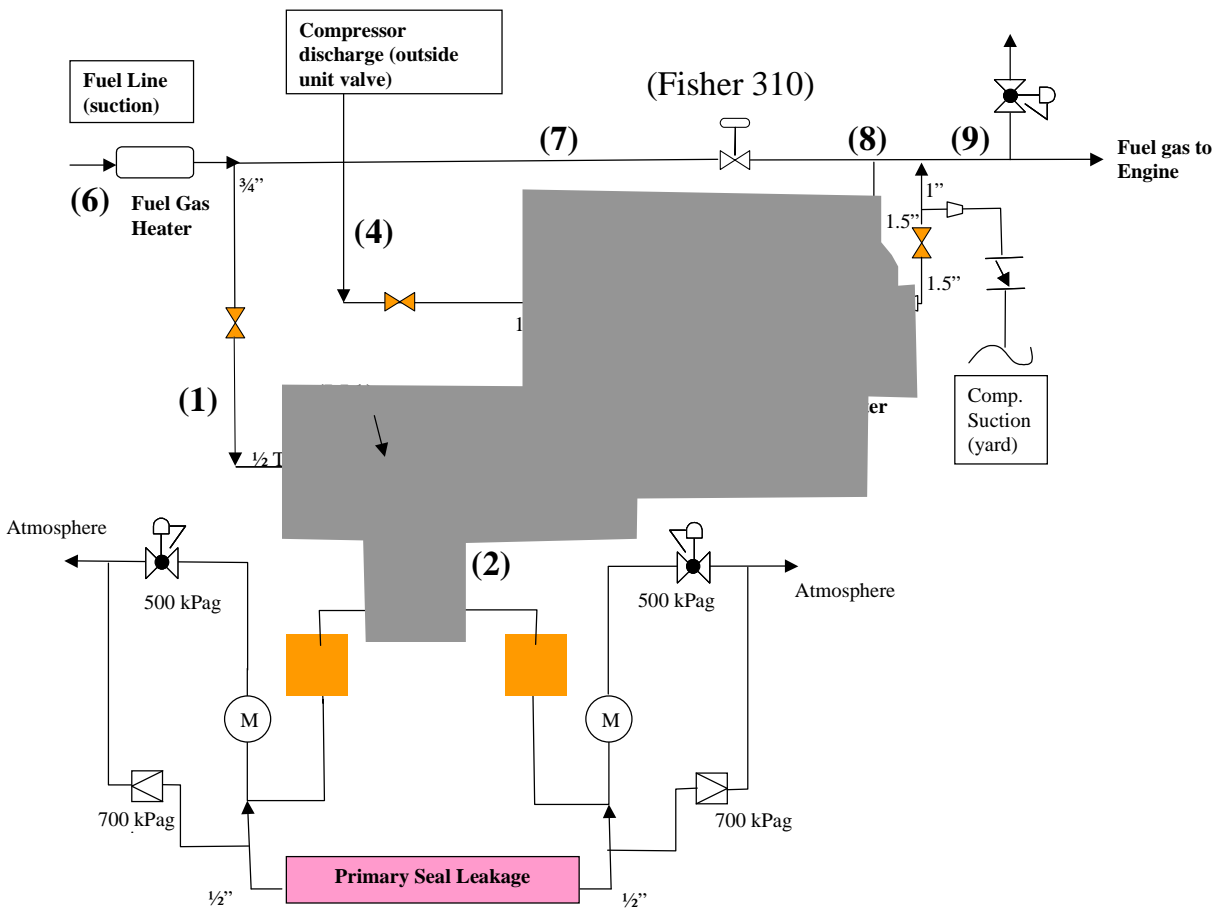

**Figure 11: Design Concept of the Two-Stage Ejector on Implementation at a 24 MW Compressor/Gas Turbine Unit on TransCanada System.**

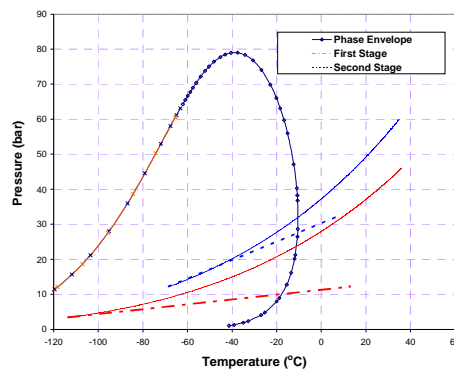

**Figure 12: Expansion and Compression Processes of the Gas Through the 1<sup>st</sup> and 2<sup>nd</sup> Stages of the Supersonic Ejector in Relation to the Phase Envelope.**



**Figure 13: Photos of the Two-Stage Supersonic Ejector Skid Connected to the Fuel Gas System at a 24 MW Gas Turbine Unit.**